

STAR WARS™



A Stern Home Arcade Original

SETUP GUIDE

1-800-KICKERS - parts.service@sternpinball.com
www.sternpinball.com - facebook.com/sternpinball

Stern Pinball machines are assembled in Elk Grove Village, Illinois, USA; each pinball machine has unique characteristics that make it a one-of-a-kind American-made product. Each machine will have variations in appearance resulting from differences in the machine's particular wood parts, digital art and mechanical assemblies. Stern Pinball has inspected each game element to ensure it meets our quality standards.

© & ™ Lucasfilm Ltd.



IMPORTANT SAFETY INSTRUCTIONS - PLEASE READ FIRST



1. Read these instructions.
2. Keep these instructions.
3. Heed all warnings.
4. Follow all instructions.
5. Do not operate this apparatus near water.
6. Clean only with a dry cloth.
7. Do not block any ventilation openings. Install in accordance with the manufacturer's instructions.
8. Do not install near any heat sources such as radiators, heat registers, stoves, or other apparatus (including amplifiers) that produce heat.
9. Do not defeat the safety purpose of the grounding type plug. A grounding type plug has two blades and a third grounding prong. The third prong is provided for your safety. If the provided plug does not fit into your outlet, consult an electrician for replacement of the obsolete outlet.
10. Protect the power cord from being walked on or pinched particularly at the plugs, convenience receptacles, and the point where they exit from the apparatus.
11. Only use attachments/accessories specified by the manufacturer.
12. Unplug this apparatus during lightning storms or when unused for long periods of time.
13. Refer all servicing to qualified service personnel. Servicing is required when the apparatus has been damaged in any way, such as if the power-supply cord or plug has been damaged, liquid has been spilled or objects have fallen into the apparatus, the apparatus has been exposed to rain or moisture, does not operate normally, or has been dropped.
14. The pinball machine shall be connected to a mains socket outlet with a protective earthing connection.
15. WARNING: To reduce the risk of fire or electric shock, do not expose apparatus to rain or moisture.
16. DO NOT expose the pinball machine to dripping and splashing. DO NOT put objects filled with liquids, such as vases, on the machine.
17. The DPDT rocker switch located under the backbox of the game turns the unit on and off. This switch cuts off both the Hot and Neutral electrical lines. This is the power switch. When the switch is depressed in the "1" position the power is ON. When depressed in the "0" position, the power is off. The power switch shall remain operable.
18. CAUTION: To reduce the risk of electric shock, servicing other than mentioned in the operating instructions should only be done by qualified service personnel unless you are qualified to do so.
19. Do not expose the battery on the CPU board, located in the top backbox, to excessive heat such as direct sunlight, fire, or other heat sources.
20. Use only legs specified by the manufacturer, or those sold with the apparatus.



Lightning in a triangle warns that there is dangerous electricity inside an appliance or product.



An exclamation mark in a triangle mean there are important instructions you should read.

CLEANING/CARE

GLASS SURFACE

USE A STANDARD HOUSEHOLD GLASS CLEANER WITH A SOFT CLOTH.

PLAYFIELD AND PLASTICS SURFACE

USE A HOUSEHOLD FURNITURE POLISH APPLIED TO A SOFT CLEAN MICROFIBER CLOTH. DO NOT SPRAY DIRECTLY ONTO SURFACE OR PLAYFIELD. AVOID DIRECT CONTACT BETWEEN LIQUIDS AND PLAYFIELD.

FOR OPTIMAL PERFORMANCE AND GAMEPLAY IT IS STRONGLY ADVISED TO CLEAN THE PLAYING SURFACE REGULARLY (I.E. EVERY 2-4 WEEKS IF USED FREQUENTLY)

LIMITED CONSUMER WARRANTY

60 DAYS LABOR

60 DAYS PARTS

9 MONTHS DISPLAY

ANY QUESTIONS CALL:

1-800-KICKERS

(542-5377)



PARTS LIST

TOOLS REQUIRED:
- 5/8" WRENCH OR SOCKET DRIVER

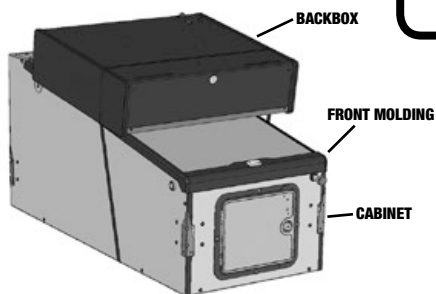

1 GAME CABINET



4 LEGS AND LEVELERS



POWER CORD



8 CABINET LEG BOLTS



4 PINBALLS



2 BACKBOX BOLTS



SETUP GUIDE

INDEX

INITIAL SETUP • 4

VOLUME ADJUSTMENT • 9

SERVICE MENU • 9

SERVICE MENU ADJUSTMENTS • 12

PLAYFIELD & CABINET ELECTRICAL • 13

DRIVER REFERENCE • 13

SWITCH REFERENCE • 15

LIGHT REFERENCE • 18

PLAYFIELD TOP ASSEMBLIES • 22

PLAYFIELD BOTTOM ASSEMBLIES • 24

PLAYFIELD RUBBER PARTS • 26

INITIAL SETUP (2 PEOPLE REQUIRED)

1 OPEN CARTON

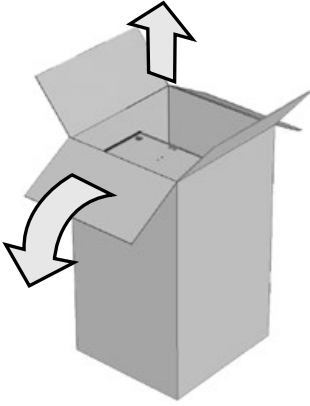

CAREFULLY TILT CARTON FORWARD ONTO THE FLOOR

2 UNBOX GAME

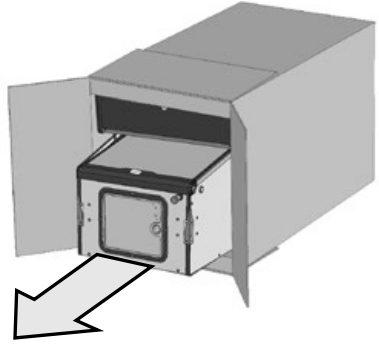

TAKE HOLD OF THE CABINET AND CAREFULLY PULL GAME OUT FROM CARTON

3 REMOVE 4 LEGS FROM CARTON

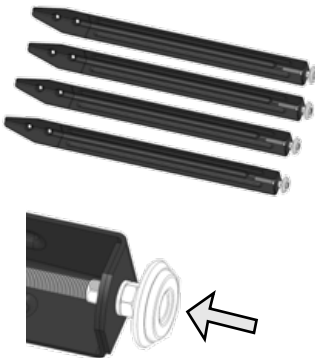

CHECK THAT BOTTOM LEG LEVELERS ARE FULLY SEATED

4 STAND GAME ON END



INSTALL BOTH FRONT LEGS EACH USING 2 OF THE BOLTS SUPPLIED WITH THE GAME

5 WITH ASSISTANCE

ROCK THE CABINET FORWARD

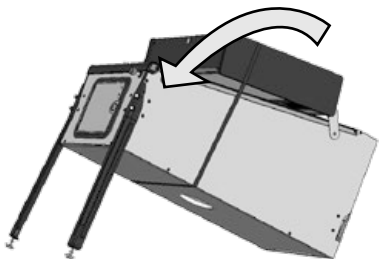

UNTIL THE FRONT LEGS ARE ON THE FLOOR

6 AGAIN, WITH ASSISTANCE, CAREFULLY LIFT THE BACK OF THE CABINET AND PLACE ON A STURDY SUPPORT OBJECT

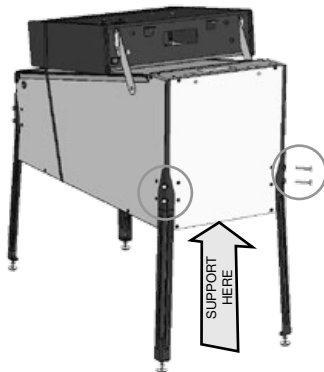

INSTALL AND TIGHTEN BOTH BACK LEGS USING 2 BOLTS EACH

7 CUT THE STRAP

SECURING THE BACKBOX TO THE REST OF THE CABINET



8 LIFT BACKBOX

UNTIL IT IS IN AN UPRIGHT POSITION

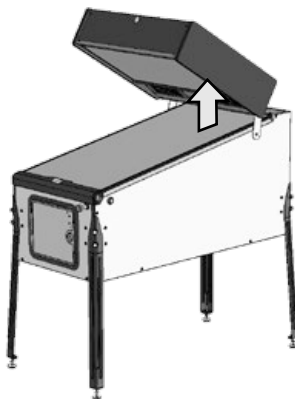

TAKE CARE TO MAKE SURE NO CABLES ARE PINCHED WHILE LIFTING THE BACKBOX

9 SECURE BACKBOX

USING THE TWO 5/8"
BACKBOX BOLTS INCLUDED

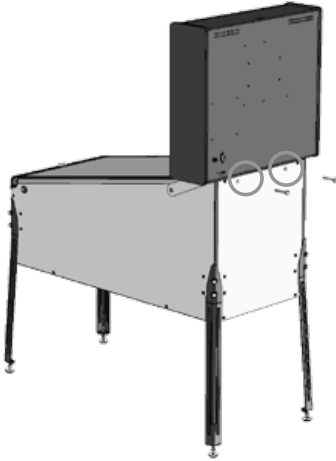

INSTALLING PINBALLS

1

REACH INSIDE THE CABINET
AND LIFT THE TWO LATCHES
LOCATED ON EITHER SIDE OF
THE FRONT DOOR

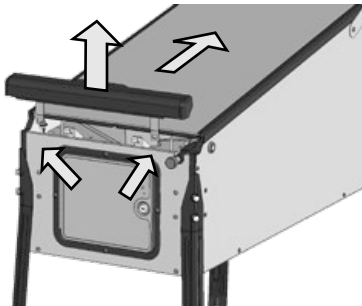

SLIDE PLAYFIELD GLASS
SLIGHTLY TOWARDS THE
BACKBOX THEN PARTIALLY
LIFT UP THE FRONT MOLDING

UNPLUG 4-PIN CONNECTOR
BEFORE FULLY LIFTING OFF
THE FRONT MOLDING

2 TO INSTALL PINBALLS

SLIDE PLAYFIELD GLASS
DOWN PARTIALLY AND PLACE
THE PINBALLS INTO THE
PLAYFIELD AREA

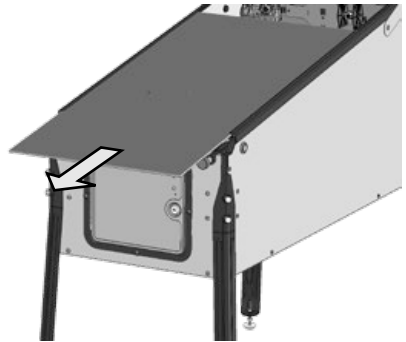

SLIDE PLAYFIELD GLASS
COMPLETELY OUT FROM
THE FRONT AND CAREFULLY
PLACE IN A SAFE AREA IF
ACCESS TO THE PLAYFIELD
IS NEEDED

TILT ADJUSTMENT

- 1** LOCATE THE TILT SENSOR INSIDE THE FRONT DOOR BY THE LEFT SIDE PANEL.
- 2** REMOVE ANY SHIPPING MATERIAL COVERING THE TILT SENSOR.
- 3** SENSITIVITY OF THE TILT HAS BEEN FACTORY ADJUSTED. IF FURTHER ADJUSTMENT IS REQUIRED, LOOSEN THUMB SCREW, ADJUST THE PLUMB BOB, AND RETIGHTEN.

NOTE: THE VERTICAL POSITION OF THE PLUMB BOB AFFECTS TILT SENSITIVITY - HIGHER MAKES THE GAME MORE SENSITIVE TO TILTING.

LEVELING

- 1** ADJUST THE FRONT OR REAR LEVELERS AS NECESSARY TO POSITION THE PLAYFIELD BUBBLE LEVEL, LOCATED ON THE FRONT RIGHT OF THE PLAYFIELD NEXT TO THE SHOOTER LANE, TO FLOAT BETWEEN THE TWO (2) BLACK LINES. THIS WILL PLACE THE PLAYFIELD AT THE RECOMMENDED 6.5° PITCH.
- 2** USE A PINBALL TO ROLL DOWN THE CENTER OF THE PLAYFIELD FOR SIDE-TO-SIDE LEVELING, OR USE AN EXTERNAL BUBBLE LEVEL, DIGITAL LEVEL, OR SMARTPHONE LEVEL APP.

INITIALIZATION

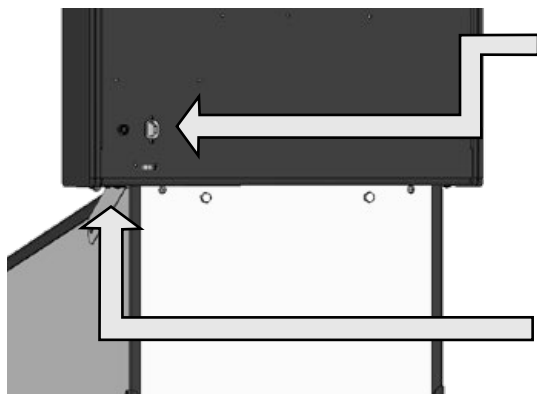

ATTACH THE POWERLINE CORD TO THE BACK OF THE GAME ON THE BACKBOX AND PLUG THE CORD INTO A 3-PRONG POWER OUTLET

FLIP THE POWER SWITCH LOCATED ON THE UNDERSIDE OF THE RIGHT EDGE OF THE BACKBOX TO POWER ON THE GAME

PLAYFIELD ACCESS

(FOR QUALIFIED SERVICE PERSONNEL ONLY)

1

UNSCREW THE BLACK PLAYFIELD KNOB AT THE BOTTOM CENTER OF THE PLAYFIELD

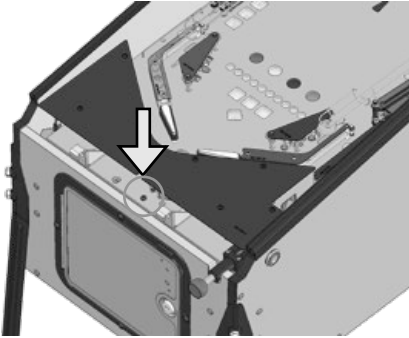

2 CAREFULLY LIFT

THE PLAYFIELD BY THE MIDDLE OF THE PLASTIC ARCH

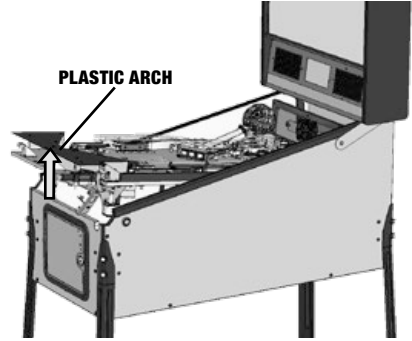

LIFT THE PLAYFIELD UP AND THEN PULL SLIGHTLY TOWARDS YOU

PLAYFIELD SHOULD STOP SLIDING AT A NOTCH ABOUT A FOOT AWAY FROM THE BACK OF THE CABINET

3

LIFT THE PLAYFIELD UP ON ITS END RESTING IT AGAINST THE BACKBOX

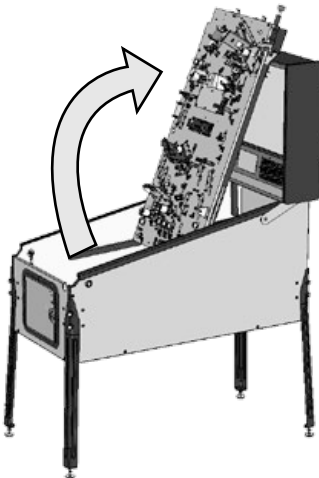

CAUTION: TAKE CARE AS PINBALLS COULD FALL OUT OF THE BALL TROUGH WHILE LIFTING THE PLAYFIELD

BACKBOX ACCESS

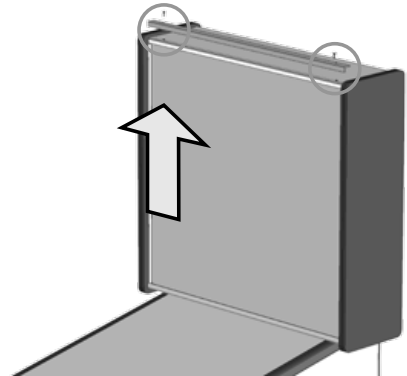

IF ACCESS TO THE BACKBOX IS NECESSARY, REMOVE 2 PHILLIPS SCREWS ON THE TOP OF THE BACKBOX

REMOVE GLASS BRACKET AND LIFT GLASS UP AND OUT

VOLUME ADJUSTMENT

Volume Menu Control:

Green -	Exit to Attract Mode
Left Red -	Decrease Volume
Right Red -	Increase Volume
Black -	Enter Service Menu

Open the door on the front of the machine to gain access to the service control buttons. The four buttons for changing settings will be located on the inside of the front door. Press the right red button to increase the volume of the game. Press the left red button to decrease the volume. The current volume will be shown on the main display.



SERVICE MENU

Service Menu Control:

Green -	Back/Escape
Left Red -	Left/Minus
Right Red -	Right/Plus
Black -	Enter/Select

Open the door on the front of the machine to gain access to the service control buttons. Press the black button to continue into the Service Menu. The left and right red buttons are used to browse the options within the Service Menu. Use the black button to select an item in the menu and see available options. The green button is used to back out of menu options, returning to the previous screen. To exit out of the Service Menu, press the green button until the game goes back into Attract Mode.

SERVICE MENU CONTINUED



DIAGNOSTICS

The Diagnostics Menu is used to access various tests to verify that your machine is working properly or to help diagnose potential problems.



SWITCH

Switch Test: Close each switch by hand and observe the display. If the switch is working properly it will display the name and corresponding number of the switch when it is activated.

Active Switch Test: Shows all active switches on the playfield. This test is useful for identifying if a switch is stuck.



COIL

Coil Test: Used to test individual coils on the playfield. Use the left and right flipper buttons to select a coil to test. Press the start button to fire the coil. CAUTION: Keep hands clear from playfield while testing coils.

Cycle Coil Test: Automatically cycles through all coils on the game to verify complete functionality. Observe the playfield and make sure each corresponding coil fires as the game cycles through each.



LAMP

LED Test: Selects individual lights to flash on the playfield. Use the left and right flipper buttons to cycle through all the lights on the game. The corresponding light flashes as it is displayed on the screen.

All LED Test: The CPU will illuminate all LEDs on the playfield. Useful for identifying possible non-functioning LEDs without cycling through every light.

G.I. (General Illumination): Lights the three general illumination areas of the playfield at the lower, middle, and upper areas of the game. Use the flipper buttons to cycle through each.



NODE

Node Test: Checks the status of the node boards. In this case the CPU Node 0 and the Playfield Core Node 8.

SERVICE MENU CONTINUED



GAME

Bank: Tests the functionality of the 3-Bank Drop Target Assembly. Manually hit the drop targets and watch the display. The display should indicate any dropped targets. Useful for checking the functionality of switches in the drop target bank. If any of the targets are recessed, press the start button to reset them.



CLEAR TROUGH

Clear Trough Test: This test allows for a simple method of removing pinballs from the trough and making sure the trough correctly detects any pinballs it is currently holding. The display should indicate if and how many pinballs are installed as well as the corresponding activated switches. Press the start button to activate the autolauncher and remove pinballs from the trough. It is a good idea to do this before intending to lift the playfield.



DOT MATRIX

Dot Matrix Test: Exercises the dot matrix display to test the illumination of all pixels in the display. No interaction is necessary. The test will continue to loop on its own. Press the launch button to exit out of the test.



ADJUSTMENTS

The Adjustments Menu is used to make changes to settings related to the gameplay of the pinball machine. Use the flipper buttons to cycle through all the game options. Press the start button to select an adjustment. The adjustment will flash when it is selected. Use the flipper buttons to change the selected adjustment and hit the start button to save the changes.

SERVICE MENU ADJUSTMENTS

STANDARD ADJUSTMENTS

ID	Adjustment Name	Default Setting
1	Replay Type	Auto
2	Replay Percentage	10
3	Replay Award	Extra Ball
4	Replay Levels	1
5	Auto Replay Start	2,000,000
11	Replay Boost	YES
12	Extra Ball Limit	5
13	Extra Ball Percentage	25
14	Balls Per Game	3
15	Tilt Warnings	2
16	Allow High Scores	YES
17	Grand Champion Awards	1
18	High Score #1 Awards	1
19	High Score #2 Awards	0
20	High Score #3 Awards	0
21	High Score #4 Awards	0
22	Grand Champion Score	2,000,000
23	High Score #1	1,750,000
24	High Score #2	1,500,000
25	High Score #3	1,000,000
26	High Score #4	750,000
27	HSTD Initials	3 Initials
28	HSTD Reset Count	2,000
29	Language	English

30	Custom Message	ON
31	Knocker Volume	LOW
32	Game Restart	YES
33	Ball Save Time	0:08
34	Timed Plunger	OFF
35	Flipper Ball Launch	OFF
37	Player Competition	NO
38	Time Format	12-Hour
39	Lost Ball Recovery	YES
44	Backbox to Cabinet Speaker Balance	30
45	Backbox Speaker Type	0
46	Cabinet Speaker Type	0
47	Master Volume Max Setting	64
48	Master Volume Min Setting	0
49	Headphones Volume Max Setting	63
50	Headphones Volume Min Setting	0
51	GI LED Brightness	100%
52	GI LED Max Brightness	255
53	Insert LED Brightness	100%
54	Insert LED Max Brightness	255
55	Flasher LED Brightness	100%
56	Flasher LED Max Brightness	255
57	Attract Mode Backbox Brightness	100%
58	Game Play Backbox Brightness	100%

FEATURE ADJUSTMENTS

ID	Adjustment Name	Default Setting
1	Double Bonus Timer	10-60 seconds (30)
2	FORCE Difficulty	EASY / HARD (EASY)
3	First Mode Start	EASY / HARD (EASY)
4	JEDI Battle Timer	30-90 seconds (60)
5	JEDI Battle Balls in Play	3-4 (4)
6	Standup Difficulty	EASY / MEDIUM / HARD (EASY)
7	Modes Difficulty	EASY / MEDIUM / HARD (MEDIUM)
8	R2-D2 Multiball	EASY / HARD (EASY)
9	Main Multiball Target Completions	1-5 (3)
10	Destroy Death Star Timer	10-45 seconds (25)
11	TIE Fighter Hurry-ups	1-5 (2)
12	R2-D2 Multiball Champion	250,000
13	R2-D2 Champion Award	CREDIT
14	R2-D2 Champion Awards	0-3 (0)
15	Death Star Multiball Champion	300,000
16	Death Star Champion Award	CREDIT
17	Death Star Champion Awards	0-3 (0)
18	TIE Fighter Multiball Champion	100,000-2,000,000 (200,000)
19	TIE Fighter Multiball Champion Award	CREDIT
20	TIE Fighter Multiball Champion Awards	0-3 (0)

21	JEDI Multiball Champion	500,000-1,500,000 (500,000)
22	JEDI Multiball Award	CREDIT
23	JEDI Multiball Awards	0-3 (0)
24	Combo Champion	2-20 (2)
25	Combo Champion Award	CREDIT
26	Combo Champion Awards	0-3 (0)
27	Bonus Champion	100,000-1,000,000 (100,000)
28	Bonus Champion Award	CREDIT
29	Bonus Champion Awards	0-3 (0)
30	Bottom Lanes	EASY / HARD (EASY)
31	Play Music In Attract Mode	NO / YES (NO)
32	Play Audio In Attract Clips	NO / YES (NO)
33	Slingshot Power	16-64 (32)
34	Disable Drop Targets	NO / YES (NO)
35	Disable Control Gates	NO / YES (NO)
36	Left Flipper Power	EASY / MEDIUM / HARD (HARD)
37	Right Flipper Power	EASY / MEDIUM / HARD (HARD)
38	Ball Launch Power	128-255 (240)
39	Drop Targets Reset Power	192-255 (222)
40	Trough Eject Power	176-255 (192)

PLAYFIELD & CABINET ELECTRICAL

STAR WARS

PIN MODEL

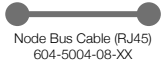
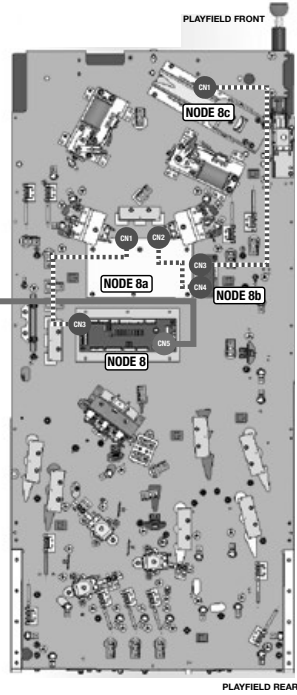
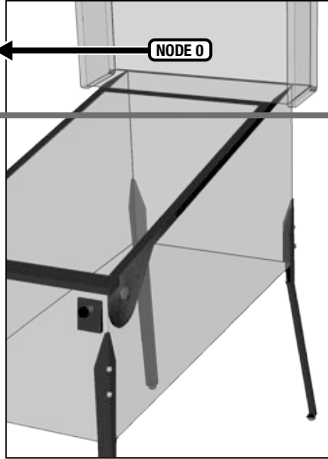
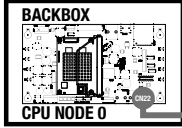

Node Bus Cable (RJ45)
604-5004-08-XX

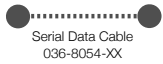

Serial Data Cable
036-8054-XX

When replacing node boards, ensure DIP address switches are set correctly!

NODE REFERENCE

ID	DIP Address	Description	Location	Part Number
Node 0	n/a	Spike 2 CPU Node	Backbox	509-1003-01
Node 8	n/a	Playfield 48V Core-Driver Node	Playfield	520-7017-72
8a	n/a	Serial LED board - Playfield-Lower	Playfield	520-7008-00
8b	n/a	Serial 16 LED Board	Playfield	520-6831-01
8c	n/a	Trough Serial Opto Receiver Extension	Playfield	520-7001-00

DRIVER REFERENCE

ID	Name	Node	Connector	Ret. Pin	Ret. Wire	Voltage	V+ Pin	V+ Color	Location	Type	Address	Part Number
1	Trough	8	CN8	7	ORG GRY	48V	3/4	GRY ORG	Playfield	Coil - 27-1500	8-DR-1	090-5004-ND
2	Auto Plunger	8	CN8	9	ORG WHT	48V	3/4	GRY ORG	Playfield	Coil - 24-940	8-DR-4	090-5036-ND
3	Left Flipper Power	8	CN8	6	ORG YEL	48V	2	GRY ORG	Playfield	Coil - 23-900	8-DR-5	090-5020-30-ND
4	Right Flipper Power	8	CN8	5	ORG GRN	48V	1	GRY ORG	Playfield	Coil - 23-900	8-DR-0	090-5020-30-ND
5	Left/Right Slingshot	8	CN7	4	ORG BLU	48V	1	GRY ORG	Playfield	Coil - 26-1200	8-DR-7	090-5044-ND
6												
7	Left/Right Pop Bumper	8	CN7	3	ORG BLK	48V	1	GRY ORG	Playfield	Coil - 26-1200	8-DR-6	090-5044-ND
8	Bottom Pop Bumper	8	CN7	2	ORG RED	48V	1	GRY ORG	Playfield	Coil - 26-1200	8-DR-8	090-5044-ND
9	3-Bank Drop Reset	8	CN8	11	ORG BRN	48V	3/4	GRY ORG	Playfield	Coil - 25-1240	8-DR-3	090-5034-ND
10	Left/Right Control Gates	8	CN8	10	ORG VIO	48V	3/4	GRY ORG	Playfield	Coil - 32-1250	8-DR-2	090-5060-01-ND

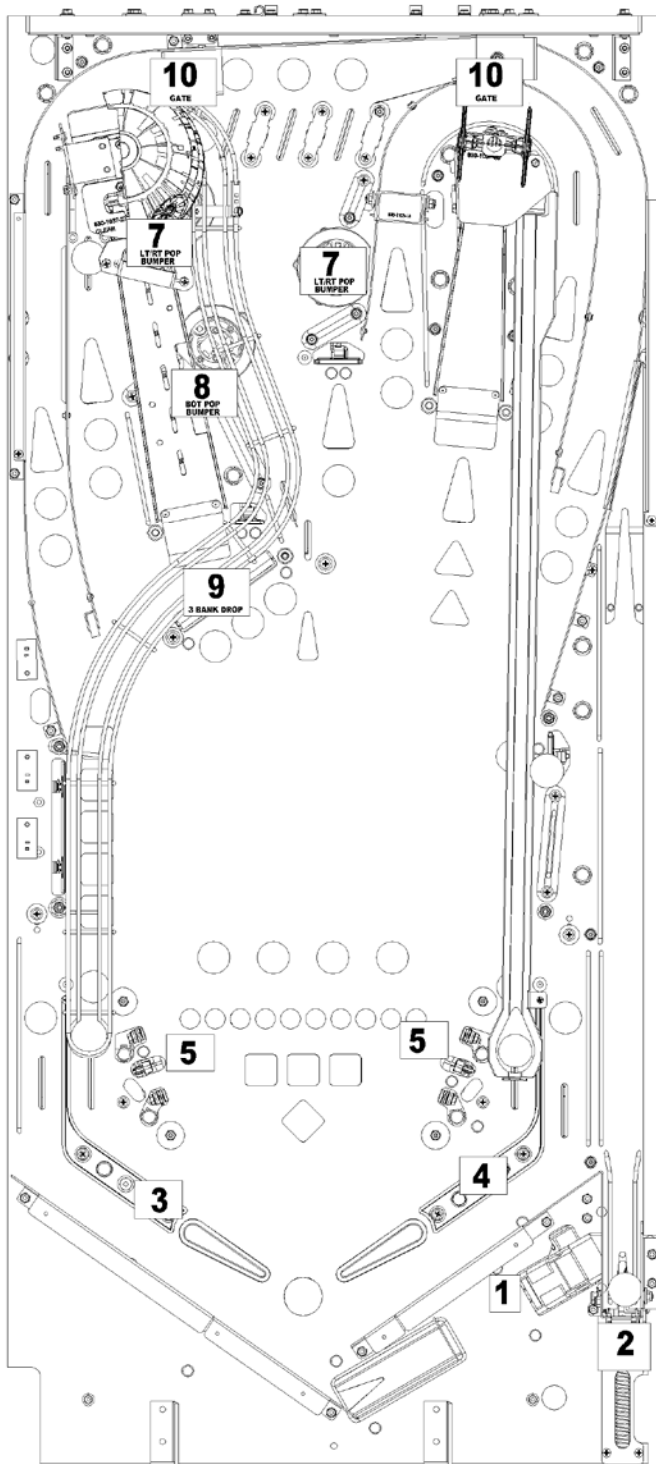

Driver Location Map

SWITCH REFERENCE

ID	Name	Node	Node Ext	Conn.	Input Pin	Input Wire	GND Pin	Ground Wire	Location	Type	Address	Part Number
1	Shooter Lane Opto	8	-	CN10	2	GRY WHT	7/8/9	BLK GRN	Playfield	Opto	8-SW-28	520-8115-00 tx 520-8116-00 rx
2	Left Outlane	8	-	CN11	4	LGN RED	11	BLK ORG	Playfield	Rollover	8-SW-17	500-9935-03
3	Left Return Lane	8	-	CN11	5	LGN ORG	11	BLK ORG	Playfield	Rollover	8-SW-18	500-9935-03
4	Right Return Lane	8	-	CN11	6	LGN YEL	11	BLK ORG	Playfield	Rollover	8-SW-19	500-9935-03
5	Right Outlane	8	-	CN11	7	LGN BLU	11	BLK ORG	Playfield	Rollover	8-SW-20	500-9935-03
6	Left Slingshot	8	-	CN10	4	GRY BLU	7/8/9	BLK GRN	Playfield	Leaf	8-SW-30	180-5231-00
7	Right Slingshot	8	-	CN10	3	GRY VIO	7/8/9	BLK GRN	Playfield	Leaf	8-SW-29	180-5231-00
8	L Flipper Button	8	-	CN9	4	GRY BRN	7	BLK GRN	Cabinet	Leaf	8-SW-25	180-5160-01R
9	Left Flipper EOS	8	-	CN10	6	GRY YEL	7/8/9	BLK GRN	Playfield	Leaf	8-SW-16	180-5149-00
10	R Flipper Button	8	-	CN9	3	GRY RED	7	BLK GRN	Cabinet	Leaf	8-SW-24	180-5160-01R
11	Right Flipper EOS	8	-	CN10	5	GRY GRN	7/8/9	BLK GRN	Playfield	Leaf	8-SW-31	180-5149-00
12												
13												
14												
15												
16	Trough 6	8	8c	CN4	-	-	-	-	Playfield	Opto	8-SW-40	520-5344-00 tx 520-7001-00 rx
17	Trough 5	8	8c	CN4	-	-	-	-	Playfield	Opto	8-SW-41	520-5344-00 tx 520-7001-00 rx
18	Trough 4	8	8c	CN4	-	-	-	-	Playfield	Opto	8-SW-42	520-5344-00 tx 520-7001-00 rx
19	Trough 3	8	8c	CN4	-	-	-	-	Playfield	Opto	8-SW-43	520-5344-00 tx 520-7001-00 rx
20	Trough 2	8	8c	CN4	-	-	-	-	Playfield	Opto	8-SW-44	520-5344-00 tx 520-7001-00 rx
21	Trough 1	8	8c	CN4	-	-	-	-	Playfield	Opto	8-SW-45	520-5344-00 tx 520-7001-00 rx
22	Trough Jam	8	8c	CN4	-	-	-	-	Playfield	Opto	8-SW-46	520-5344-00 tx 520-7001-00 rx
23												
24	FORCE Target Bottom	8	8a	CN10	2	TAN BLK	10	BLK YEL	Playfield	Leaf, Target	8-SW-32	511-2777-00
25	FORCE Target Top	8	8a	CN10	3	TAN RED	10	BLK YEL	Playfield	Leaf, Target	8-SW-33	511-2777-00
26	Yoda Mystery Target	8	8a	CN10	4	TAN ORG	10	BLK YEL	Playfield	Leaf, Target	8-SW-34	515-9784-00-00
27												
28												
29												
30												
31	Left Luke Orbit	8	-	CN13	5	PNK ORG	10	BLK BRN	Playfield	Rollover	8-SW-3	500-9935-04
32	Hidden Target	8	-	CN13	6	PNK YEL	10	BLK BRN	Playfield	Leaf, Target	8-SW-4	515-9783-00-00
33	Death Star Target	8	-	CN13	3	PNK BRN	10	BLK BRN	Playfield	Leaf, Target	8-SW-1	515-9784-00-01
34	Top Lane Left	8	-	CN13	7	PNK GRN	10	BLK BRN	Playfield	Rollover	8-SW-5	500-9935-03
35	Top Lane Center	8	-	CN13	8	PNK BLU	10	BLK BRN	Playfield	Rollover	8-SW-6	500-9935-03
36	Top Lane Right	8	-	CN13	9	PNK VIO	10	BLK BRN	Playfield	Rollover	8-SW-7	500-9935-03
37	Left Pop Bumper	8	-	CN12	9	WHT GRY	10	BLK RED	Playfield	Leaf	8-SW-15	180-5232-00
38	Bottom Pop Bumper	8	-	CN13	4	PNK RED	10	BLK BRN	Playfield	Leaf	8-SW-2	180-5232-00

SWITCH REFERENCE CONTINUED

ID	Name	Node	Node Ext	Conn.	Input Pin	Input Wire	GND Pin	Ground Wire	Location	Type	Address	Part Number
39	Right Pop Bumper	8	-	CN13	2	PNK BLK	10	BLK BRN	Playfield	Leaf	8-SW-0	180-5232-00
40	Han Ramp Enter	8	-	CN11	2	LGN BLK	11/12	BLK ORG	Playfield	Rollover	8-SW-26	500-9935-03
41	Han Ramp Exit Opto	8	-	CN11	3	LGN BRN	11/12	BLK ORG	Playfield	Opto	8-SW-27	520-8115-00 tx 520-8116-00 rx
42												
43	3-Bank Drop Tgt Left	8	-	CN11	8	LGN VIO	12	BLK ORG	Playfield	Opto	8-SW-21	520-5252-13
44	3-Bank Drop Tgt Center	8	-	CN11	9	LGN GRY	12	BLK ORG	Playfield	Opto	8-SW-22	520-5252-13
45	3-Bank Drop Tgt Right	8	-	CN11	10	LGN WHT	12	BLK ORG	Playfield	Opto	8-SW-23	520-5252-13
46												
47	Center Target	8	-	CN12	2	WHT BRN	10	BLK RED	Playfield	Leaf, Target	8-SW-8	515-9784-00-00
48	R2-D2 Lock 1	8	-	CN12	3	WHT RED	10	BLK RED	Playfield	Opto	8-SW-9	520-8115-00 tx 520-8116-00 rx
49	Leia Spinner Opto	8	-	CN12	4	WHT ORG	10	BLK RED	Playfield	Opto	8-SW-10	520-8115-00 tx 520-8116-00 rx
50	Leia Orbit	8	-	CN12	5	WHT YEL	10	BLK RED	Playfield	Rollover	8-SW-11	500-9935-03
51	Right Luke Orbit	8	-	CN12	6	WHT GRN	10	BLK RED	Playfield	Rollover	8-SW-12	500-9935-03
52	Right Ramp Target	8	-	CN12	7	WHT BLU	10	BLK RED	Playfield	Leaf, Target	8-SW-13	515-9784-00-01
53	R2-D2 Lock 2	8	-	CN12	8	WHT VIO	10	BLK RED	Playfield	Opto	8-SW-14	520-8115-00 tx 520-8116-00 rx
54												
55												
56	Start Button	8	8a	CN10	5	GRY	10	BLK YEL	Cabinet	Micro	8-SW-35	500-2490-04-LED
57												
58	Tilt Pendulum	8	8a	CN10	6	WHT	10	BLK YEL	Cabinet	Plumb Bob	8-SW-36	516-0007-00
59												
C1												
C10	Service Plus	0	-	CN25	3	LGN VIO	6	BLK	Coin Door		0-SW-9	515-1963-00
C11	Service Minus	0	-	CN25	2	LGN BLU	6	BLK	Coin Door		0-SW-10	515-1963-00
C12	Service Back	0	-	CN25	1	LGN BLK	6	BLK	Coin Door		0-SW-11	515-1963-00
C17	Headphone Detect	0	-	-	-	-	-	-	Coin Door		0-SW-16	-
C18	Headphone Kit Cable Detect	0	-	CN3	5	BLK	4	BLK	CPU Node		0-SW-17	-
C19	Volume Encoder 1	0	-	CN3	6	WHT	1	DRAIN	CPU Node		0-SW-18	-
C2												
C20	Volume Encoder 2	0	-	CN3	7	GRN	1	DRAIN	CPU Node		0-SW-19	-
C24	DC Sense	0	-	CN7	4	GRY RED	1	BLK	-		0-SW-23	-
C3												
C4												
C5												
C6												
C7												
C8												
C9	Service Select	0	-	CN25	4	LGN GRY	6	BLK	Coin Door		0-SW-8	515-1963-00

LIGHT REFERENCE

ID	Name	Node	Node Ext.	Conn.	Ret. Pin	Ret. Wire	Src. Pin	Src. Wire	Location	Type	Light Color	Address	Part Number
1	Left Outlane	8	-	CN14	6	ORG VIO	7/8	YEL	Playfield	Feature	White	8-LP-3	520-5307-00
2	Left Return Lane	8	-	CN14	5	ORG BLU	7/8	YEL	Playfield	Feature	White	8-LP-4	520-5307-00
3	Right Return Lane	8	-	CN14	4	ORG YEL	7/8	YEL	Playfield	Feature	White	8-LP-5	520-5307-00
4	Right Out-lane	8	-	CN14	3	ORG	7/8	YEL	Playfield	Feature	White	8-LP-6	520-5307-00
5	Shoot Again	8	-	CN14	2	ORG RED	7/8	YEL	Playfield	Feature	White	8-LP-7	520-5307-00
6													
7	Start	8	8b	CN2	1	YEL BLK	7/8	RED	Cabinet	Feature	White	8-LP-70	500-2490-04-LED
8													
9													
10	HAN	8	8a	-	LED11	-	-	-	Playfield	Feature	White	8-LP-18	520-7008-00
11	LEIA	8	8a	-	LED12	-	-	-	Playfield	Feature	White	8-LP-19	520-7008-00
12	R2-D2	8	8a	-	LED13	-	-	-	Playfield	Feature	White	8-LP-20	520-7008-00
13	LUKE	8	8a	-	LED14	-	-	-	Playfield	Feature	White	8-LP-21	520-7008-00
14	Bonus 1	8	8a	-	LED1	-	-	-	Playfield	Feature	White	8-LP-8	520-7008-00
15	Bonus 2	8	8a	-	LED2	-	-	-	Playfield	Feature	White	8-LP-9	520-7008-00
16	Bonus 3	8	8a	-	LED3	-	-	-	Playfield	Feature	White	8-LP-10	520-7008-00
17	Bonus 4	8	8a	-	LED4	-	-	-	Playfield	Feature	White	8-LP-11	520-7008-00
18	Bonus 5	8	8a	-	LED5	-	-	-	Playfield	Feature	White	8-LP-12	520-7008-00
19	Bonus 10	8	8a	-	LED6	-	-	-	Playfield	Feature	White	8-LP-13	520-7008-00
20	Bonus 20	8	8a	-	LED7	-	-	-	Playfield	Feature	White	8-LP-14	520-7008-00
21	Bonus 30	8	8a	-	LED8	-	-	-	Playfield	Feature	White	8-LP-15	520-7008-00
22	Bonus 40	8	8a	-	LED9	-	-	-	Playfield	Feature	White	8-LP-16	520-7008-00
23	Bonus ?	8	8a	-	LED10	-	-	-	Playfield	Feature	White	8-LP-17	520-7008-00
24													
25	2x	8	8a	CN3	2	YEL BRN	1	RED	Playfield	Feature	White	8-LP-22	520-7011-00
26	3x	8	8a	CN3	3	YEL ORG	1	RED	Playfield	Feature	White	8-LP-23	520-7011-00
27	Double Scoring	8	8a	CN3	4	YEL GRN	1	RED	Playfield	Feature	White	8-LP-24	520-7011-00
28	Jedi Multiball	8	8a	CN3	5	ORG GRY	1	RED	Playfield	Feature	White	8-LP-25	520-5307-00
29													
30	(F)ORCE	8	8a	CN9	9	GRN GRY	1	RED	Playfield	Feature	White	8-LP-62	520-5307-00
31	F(O)RCE	8	8a	CN9	10	GRN WHT	1	RED	Playfield	Feature	White	8-LP-63	520-5307-00
32	FO(R)CE	8	8a	CN4	2	BRN BLK	1	RED	Playfield	Feature	White	8-LP-26	520-7011-00
33	FOR(C)E	8	8a	CN4	3	BRN	1	RED	Playfield	Feature	White	8-LP-27	520-7011-00
34	FORC(E)	8	8a	CN4	4	BRN RED	1	RED	Playfield	Feature	White	8-LP-28	520-7011-00
35	Yoda Mystery	8	8a	CN9	8	GRN VIO	1	RED	Playfield	Feature	White	8-LP-61	520-5307-00
36													
37	Left Luke 10K	8	8a	CN4	5	BRN ORG	1	RED	Playfield	Feature	White	8-LP-29	520-7011-00
38	Left Luke 25K	8	8a	CN4	6	BRN YEL	1	RED	Playfield	Feature	White	8-LP-30	520-7011-00
39	Left Luke Arrow	8	8a	CN4	7	BRN GRN	1	RED	Playfield	Feature	White	8-LP-31	520-7011-00
40													
41	Left Han 10K	8	8a	CN4	8	BRN BLU	1	RED	Playfield	Feature	White	8-LP-32	520-7011-00
42	Left Han 25K	8	8a	CN4	9	BRN VIO	1	RED	Playfield	Feature	White	8-LP-33	520-7011-00
43	Left Han Arrow	8	8a	CN4	10	BRN GRY	1	RED	Playfield	Feature	White	8-LP-34	520-7011-00
44													
45	3-Bank Drop Tgt Left	8	8a	CN7	4	BLU ORG	1	RED	Playfield	Feature	White	8-LP-44	520-7011-00

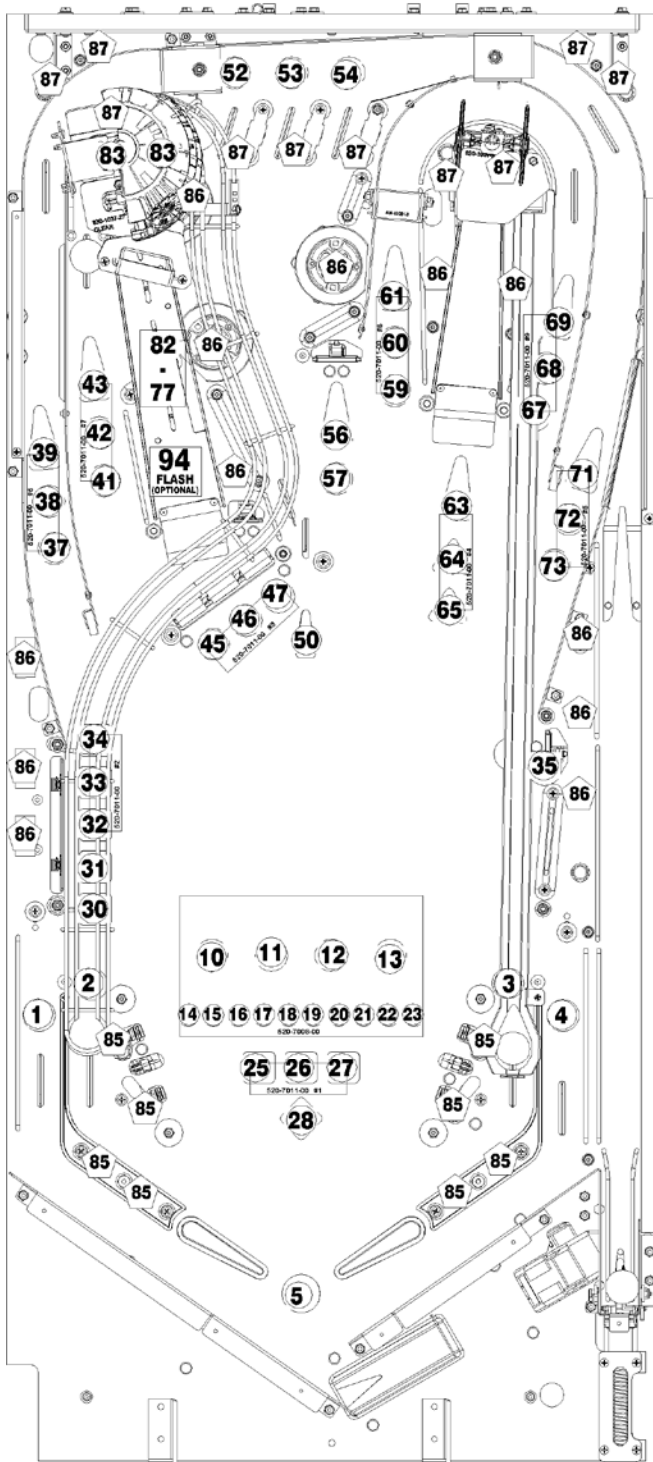

96 FLASH	97 FLASH	98 FLASH
-------------	-------------	-------------

10	11	12	13
14	15	16	17
18	19	20	21
22	23		
520-7000-00			
25	26	27	
520-7011-00 #1			
28			

Light Location Map

LIGHT REFERENCE CONTINUED

ID	Name	Node	Node Ext.	Conn.	Ret. Pin	Ret. Wire	Src. Pin	Src. Wire	Location	Type	Light Color	Address	Part Number
46	3-Bank Drop Tgt Center	8	8a	CN7	3	BLU RED	1	RED	Playfield	Feature	White	8-LP-43	520-7011-00
47	3-Bank Drop Tgt Right	8	8a	CN7	2	BLU BRN	1	RED	Playfield	Feature	White	8-LP-42	520-7011-00
48													
49													
50	R2-D2 Multiball	8	8a	CN6	8	ORG GRY	1	RED	Playfield	Feature	White	8-LP-41	520-5307-00
51													
52	Top Lane Left	8	8a	CN6	2	YEL VIO	1	RED	Playfield	Feature	White	8-LP-35	520-5307-00
53	Top Lane Center	8	8a	CN6	3	YEL GRY	1	RED	Playfield	Feature	White	8-LP-36	520-5307-00
54	Top Lane Right	8	8a	CN6	4	YEL WHT	1	RED	Playfield	Feature	White	8-LP-37	520-5307-00
55													
56	R2-D2 Arrow	8	8a	CN6	6	ORG BRN	1	RED	Playfield	Feature	White	8-LP-39	520-5307-00
57	Extra Ball	8	8a	CN6	5	ORG BLK	1	RED	Playfield	Feature	White	8-LP-38	520-5307-00
58													
59	Leia Spinner 10K	8	8a	CN7	5	BLU YEL	1	RED	Playfield	Feature	White	8-LP-45	520-7011-00
60	Leia Spinner 25K	8	8a	CN7	6	BLU GRN	1	RED	Playfield	Feature	White	8-LP-46	520-7011-00
61	Leia Spinner Arrow	8	8a	CN7	7	BLU	1	RED	Playfield	Feature	White	8-LP-47	520-7011-00
62													
63	Right Ramp Arrow	8	8a	CN7	8	BLU VIO	1	RED	Playfield	Feature	White	8-LP-48	520-7011-00
64	TIE Fighter Multiball	8	8a	CN7	9	BLU GRY	1	RED	Playfield	Feature	White	8-LP-49	520-7011-00
65	TIE Fighter Hurry Up	8	8a	CN7	10	BLU WHT	1	RED	Playfield	Feature	White	8-LP-50	520-7011-00
66													
67	Leia 10K	8	8a	CN9	2	GRN BRN	1	RED	Playfield	Feature	White	8-LP-55	520-7011-00
68	Leia 25K	8	8a	CN9	3	GRN RED	1	RED	Playfield	Feature	White	8-LP-56	520-7011-00
69	Leia Arrow	8	8a	CN9	4	GRN ORG	1	RED	Playfield	Feature	White	8-LP-57	520-7011-00
70													
71	Right Luke Arrow	8	8a	CN9	5	GRN YEL	1	RED	Playfield	Feature	White	8-LP-58	520-7011-00
72	Right Luke 25K	8	8a	CN9	6	GRN	1	RED	Playfield	Feature	White	8-LP-59	520-7011-00
73	Right Luke 10K	8	8a	CN9	7	GRN BLU	1	RED	Playfield	Feature	White	8-LP-60	520-7011-00
74													
75													
76													
77	Ramp 1	8	8b	CN2	7	YEL GRY	8/9	RED	Playfield	Feature	White	8-LP-64	520-7011-00
78	Ramp 2	8	8b	CN2	6	YEL BLU	8/9	RED	Playfield	Feature	White	8-LP-65	520-7011-00
79	Ramp 3	8	8b	CN2	5	YEL GRN	8/9	RED	Playfield	Feature	White	8-LP-66	520-7011-00
80	Ramp 4	8	8b	CN2	4	YEL ORG	8/9	RED	Playfield	Feature	White	8-LP-67	520-7011-00
81	Ramp 5	8	8b	CN2	3	YEL RED	8/9	RED	Playfield	Feature	White	8-LP-68	520-7011-00
82	Ramp 6	8	8b	CN2	2	YEL BRN	8/9	RED	Playfield	Feature	White	8-LP-69	520-7011-00
83	Death Star (X2)	8	8a	CN8	2	GRN BLK	1	RED	Playfield	Feature	Green	8-LP-51	520-5333-00
84													

LIGHT REFERENCE CONTINUED

ID	Name	Node	Node Ext.	Conn.	Ret. Pin	Ret. Wire	Src. Pin	Src. Wire	Location	Type	Light Color	Address	Part Number
85	Playfield Gl 1	8	-	CN15	5	WHT BLK	1	YEL BLK	Playfield	G.I.	White	8-LP-0	112-5034-WW
86	Playfield Gl 2	8	-	CN15	6	RED BLK	2	YEL RED	Playfield	G.I.	White	8-LP-1	112-5034-WW 520-8059- 00(POPS) 520- 5307-00(TOP Gl)
87	Playfield Gl 3	8	-	CN15	7	BLU BLK	3	YEL BLU	Playfield	G.I.	White	8-LP-2	112-5034-WW
88													
89													
90													
91													
92													
93													
94	Millennium Falcon (Optional)	8	8a	CN6	7	ORG- GRN	1	RED	Playfield	Flash	White	8-LP-40	520-7000-00
95													
96	Backpanel Flash L	8	8a	CN8	3	ORG RED	1	RED	Playfield	Flash	White	8-LP-52	520-7000-00
97	Backpanel Flash C	8	8a	CN8	4	ORG YEL	1	RED	Playfield	Flash	White	8-LP-53	520-7000-00
98	Backpanel Flash R	8	8a	CN8	5	ORG BLU	1	RED	Playfield	Flash	White	8-LP-54	520-7000-00
99													

PLAYFIELD TOP ASSEMBLIES

ID	Part Number	Description	Qty
1	500-2496-00	Shooter Assembly	1
2	515-5133-08-06	Flipper Bat	2
3	511-2778-00	Left Wireform Ramp	1
4	515-2077-00	Right Wireform Ramp	1
5	626-5057-01	Rubber Pad	2
6	510-1017-00	Left Ramp	1
7	510-1018-00	Right Ramp	1
8	511-2775-00	Spinner Assembly	1
9	535-9051-00	Shooter Lane Ramp	1
10	511-7989-00	Death Star (Left)	1
	511-1050-01	Death Star (Right)	1
11	500-2487-00	TIE Fighter	1
12	511-2781-00	Gate Assembly (Left)	1
13	511-5096-01-L8	Gate Assembly (Right)	1

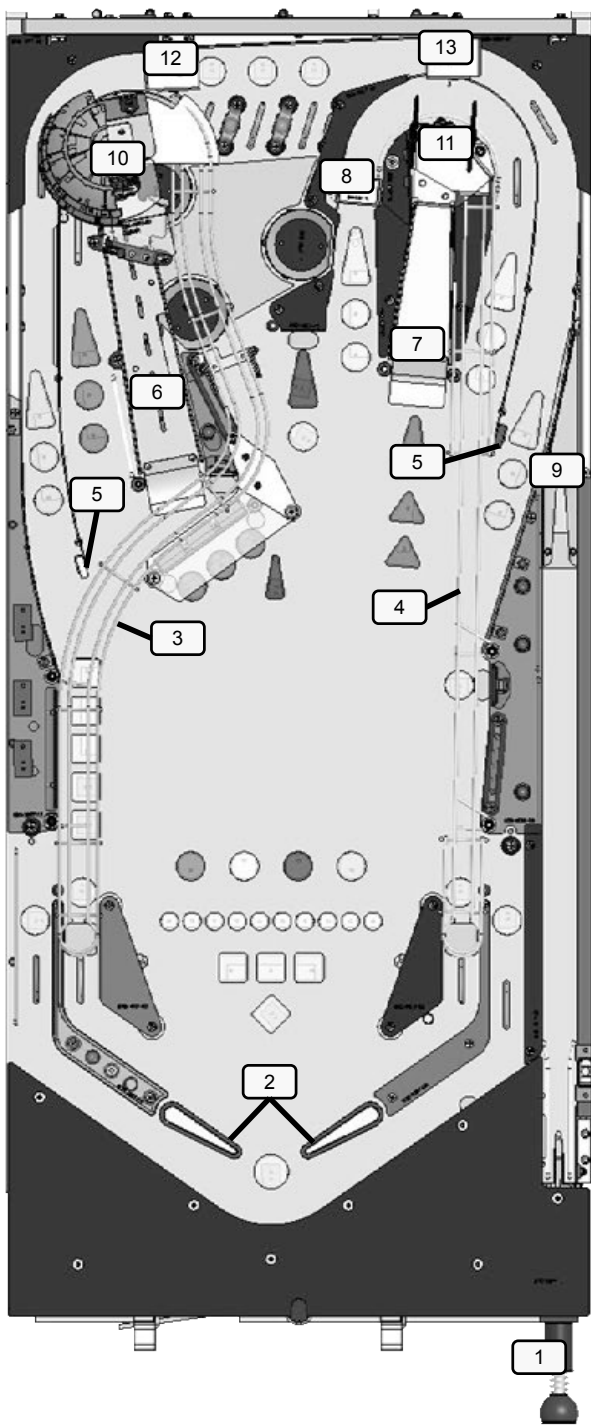

PLAYFIELD BOTTOM ASSEMBLIES

ID	Part Number	Description	Qty
1	500-1177-00	Auto Launch Assembly	1
2	500-9820-L8	Trough Assembly	1
3	500-6543-13-ND	Left Flipper Assembly	1
4	500-6543-03-ND	Right Flipper Assembly	1
5	500-9920-01	Left Slingshot	1
6	500-9920-01	Right Slingshot	1
7	520-7011-00	3-LED Board	9
8	520-7008-00-L8	Center LED Board	1
9	500-7216-13	Drop Target Assembly	1
10	520-6831-01	Serial LED Board	1
11	515-6459-04-ND	Pop Bumper - Bottom Assembly	3
12	511-2771-31	Optic Switch	1

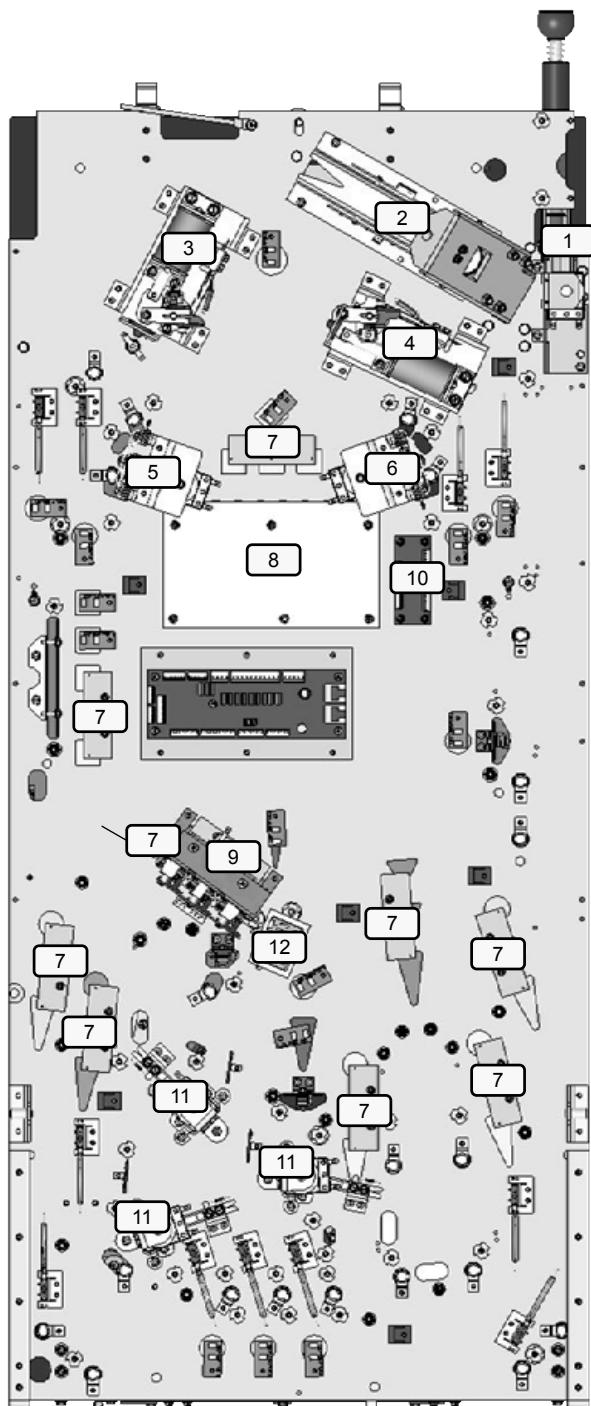

PLAYFIELD RUBBER PARTS

ID	Qty	Size (ID)	Size (OD)	Durometer	Color	Part Number
1	6	3/16"		50	Black	545-5348-01
2	3	5/16"		50	Black	545-5348-02
3	1	3/4"		50	Black	545-5348-04
4	3	1"		50	Black	545-5348-05
5	2	1-1/2"		50	Black	545-5348-07
6	3	2-1/2"		50	Black	545-5348-09
7	3		7/16"	50	Black	545-5348-17

ID	Qty	Description	Color	Part Number
8	2	Flipper Rubber	Black	545-5277-00
9	1	Plunger Tip	Black	545-5276-00
10	9	Post Rubber	Black	545-5308-00

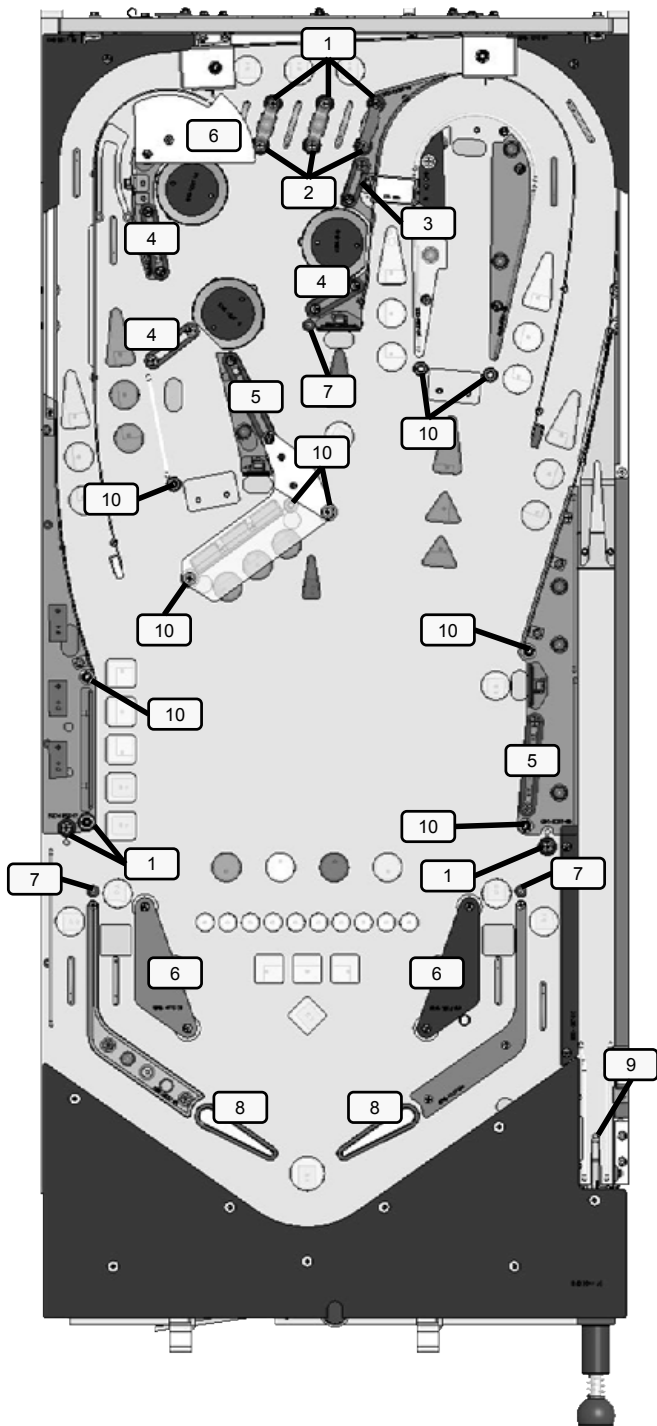



1-800-KICKERS

PARTS.SERVICE@STERNPINBALL.COM

WWW.STERNPINBALL.COM

FACEBOOK.COM/STERNPINBALL

STAR WARS #500-55L8-01

MANUAL #780-50L8-00

